

Provided for non-commercial research and education use.
Not for reproduction, distribution or commercial use.

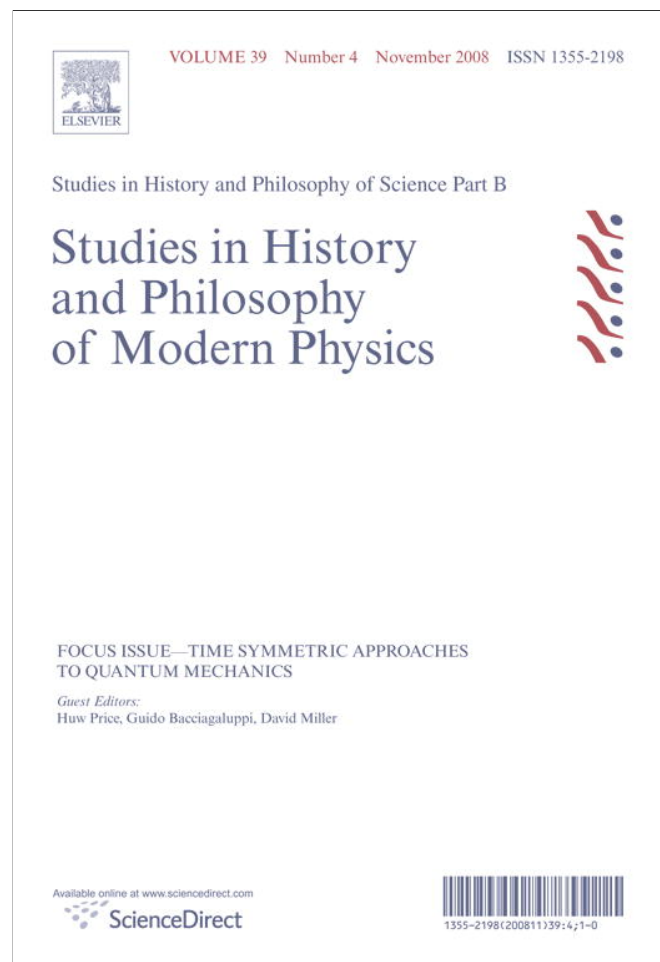

This article appeared in a journal published by Elsevier. The attached copy is furnished to the author for internal non-commercial research and education use, including for instruction at the authors institution and sharing with colleagues.

Other uses, including reproduction and distribution, or selling or licensing copies, or posting to personal, institutional or third party websites are prohibited.

In most cases authors are permitted to post their version of the article (e.g. in Word or Tex form) to their personal website or institutional repository. Authors requiring further information regarding Elsevier's archiving and manuscript policies are encouraged to visit:

<http://www.elsevier.com/copyright>



ELSEVIER

Contents lists available at ScienceDirect

Studies in History and Philosophy of Modern Physics

journal homepage: www.elsevier.com/locate/shpsb

Why quantum mechanics favors adynamical and acausal interpretations such as relational blockworld over backwardly causal and time-symmetric rivals

Michael Silberstein^{a,b,*}, Michael Cifone^b, William Mark Stuckey^c^a Department of Philosophy, Wenger Center, Elizabethtown College, Elizabethtown, PA 17022, USA^b Department of Philosophy, Skinner Building, University of Maryland, College Park, MD 20742, USA^c Department of Physics, Esbenshade Building, Elizabethtown College, Elizabethtown, PA 17022, USA

ARTICLE INFO

Article history:

Received 19 July 2008

Received in revised form

19 July 2008

Keywords:

Time-symmetric quantum mechanics

Blockworld

Locality

Backwards causation

Relational Blockworld

Hidden variable

ABSTRACT

We articulate the problems posed by the quantum liar experiment (QLE) for backwards causation interpretations of quantum mechanics, time-symmetric accounts and other dynamically oriented local hidden variable theories. We show that such accounts cannot save locality in the case of QLE merely by giving up “lambda-independence.” In contrast, we show that QLE poses no problems for our acausal Relational Blockworld interpretation of quantum mechanics, which invokes instead adynamical global constraints to explain Einstein–Podolsky–Rosen (EPR) correlations and QLE. We make the case that the acausal and adynamical perspective is more fundamental and that dynamical entities obeying dynamical laws are emergent features grounded therein.

© 2008 Elsevier Ltd. All rights reserved.

When citing this paper, please use the full journal title *Studies in History and Philosophy of Modern Physics*

* Corresponding author at: Department of Philosophy, Wenger Center, Elizabethtown College, Elizabethtown, PA 17022, USA.

E-mail address: silbermd@etown.edu (M. Silberstein).

0. Introduction

We believe that (especially if one is interested in saving locality and thereby securing consistency with special relativity (SR)) certain quantum mechanical experiments like the quantum liar experiment (QLE) imply that quantum mechanics (QM) is deeply *contextual* in a way that calls into serious question *any* common-cause principle and *any* account of QM that relies on “interactive forks” to explain, for example, Einstein–Podolsky–Rosen (EPR) correlations (Einstein, Podolsky, & Rosen, 1935). Our Relational Blockworld interpretation (RBW) has the explanatory capability to handle the contextuality (what we shall call “spatiotemporal contextuality”) revealed in QLE while also preserving locality. RBW is an adynamical account of non-relativistic quantum mechanics (NRQM) that invokes *acausal and adynamical global* constraints and is therefore not in essential conflict with SR. Unlike Huw Price’s backwards causation QM (BCQM) account (Price, 1996) for example, we reject any kind of common-cause principle. Like BCQM and time-symmetric QM (TSQM)¹ and various local hidden variable theories,² RBW is consistent with the denial of the “lambda-independence” assumption (that the *past* states of the hidden variables do not depend on their *future* states) in Bell’s Theorem, but RBW does not rely on that fact to preserve locality.

Indeed, what will be made clear is that denying the lambda-independence assumption is not sufficient to preserve locality and furthermore that the other accounts all fail as complete interpretations, whether on more general grounds such as the measurement problem or in their lack of ability to explain QLE with locality intact. Section 1 will introduce the reader to RBW, Section 2 will show why no extant account of BCQM, TSQM or local hidden variable theories more generally can clearly explain QLE while maintaining locality and Section 3 will summarize the RBW acausal global constraint account of QLE.

1. RBW: radically Archimedean physics

1.1. Blockhead dreams

Others have suggested that we ought to take the fact of blockworld (BW) seriously when doing physics and modeling reality. For example, Huw Price (1996, p. 4) calls it the “Archimedean view from nowhen” and it has motivated him to take seriously the idea of a TSQM and so-called backwards causation in QM. As he says in his book defending BCQM: “the aim of the book is to explore the consequences of the block universe view in physics and philosophy” (Price, 1996, p. 15). Price is attempting to construct a local hidden variables interpretation of NRQM that explains EPR correlations with purely time-like dynamics or backwards causation. According to Price, BCQM provides an explanation of the Bell correlations “which shows that they are not really non-local at all, in that they depend on purely *local* interactions between particles and measuring devices concerned. They *seem* non-local only if we overlook the present relevance of future interactions” (Price, 1996, p. 224). The key explanatory move that Price makes is to have information travel backwards along the light cones of the two EPR particles, converging at the source of the entangled state. Presumably, this is the point in spacetime where the entangled state is “prepared.” The picture we must think of is this: the future measurement interaction in separate wings of an EPR apparatus is the cause of the (earlier) entangled state, so the point at which they are created is the “effect” of a causal chain “originating” with the measurement interaction. That is, the effect of the causal chain originating with the measurement interaction is the directions in which the spin components of the particles

¹ There are many varieties of TSQM now in the literature. To name a few: there is the “two-vector” reconstruction of QM advocated by Aharonov and his collaborators (see e.g., Aharonov, Botero, Popescu, Reznik, & Tollaksen, 2002), which centers around the Aharonov–Bergmann–Lebowitz rule (Aharonov, Bergmann, & Lebowitz, 1964)—hereafter, “TSQM-ABL”, the “transactional interpretation” (Cramer, 1980, 1986), and the recent version of TSQM by Wharton (2007), which claims to be “the first attempt to combine the symmetric aspects of ... previous proposals”. Wharton’s proposal applies “two symmetric boundary conditions [as with TSQM-ABL] onto a time-symmetric version of the Schrödinger equation [as with Cramer’s interpretation]” (Wharton, 2007, p. 160).

² See Lewis (2006, 2007) for example.

have determinate values at the point at which they are created. This is to put the point directly in terms of *backwards* causation. The arrow of causation does not point from one spacelike separated wing of the apparatus to the other, across *space*, but rather it points backwards in *time* to the point at which the particles are created—indeed, there are causal “influences” flowing in both directions along the particle trajectories.

The connection between BCQM or even time-symmetric accounts of the quantum and the BW seems straightforward at first: in a BW the state preparations and measurement outcomes are equally real, i.e., already “there” (which is not to say equally present). Thus, since a dynamic interpretation or explanation of the BW picture is secondary in some sense, one might as well claim the measurement outcomes “effect the state preparations” rather than the converse. However, upon inspection, it is not obvious that BW entails BCQM or the reverse: a theory of causation is required for starters. Of course it may seem trivial to explain the outcomes of quantum experiments (or anything else) using the BW. After all, one could answer *any* question in this vein by saying something like “it is all just there in the BW, end of story” (see Barrett, 2005). In order to avoid trivializing the BW explanation, BW motivated interpretations of NRQM invoke clever devices such as time-like backwards causation, advanced action and the two-vector formalism. Do these beautiful and clever devices really avoid the charge of triviality and do they really involve the BW hypothesis essentially? An answer in the negative will be given in Section 2.

We cannot speak for Price and others, but for us the BW motivation is not just about preserving locality, nor even just peaceful co-existence with the relativity of simultaneity, but rather it is our belief that taking the BW seriously suggests the possibility for radically “Archimedean” solutions to many of the problems in QM, such as how to interpret EPR correlations and the measurement problem. Thus we are bothered by the fact that BCQM and TSQM explanations are no less *dynamical* than standard QM, which is puzzling if part of the original BW motivation for such accounts is that the BW lacks *absolute* change and becoming. As far as we know, only Cramer speaks to this worry directly. Cramer notes that the backwards-causal elements of his theory are “only a pedagogical convention,” and that in fact “the process is atemporal” (Cramer, 1986, p. 661). In all fairness, Price (2007) does emphasize the “perspectival” nature of causal explanations. BCQM and the like, even having acknowledged the potential explanatory importance of BW, have not, as will become clear, gone far enough in their atemporal, acausal and adynamical thinking. Whereas such accounts are willing to think backwardly, temporally speaking, it is still essentially *dynamical*, *temporal* thinking. All of this poses a dilemma, to exploit BW in an *essential* and *non-trivial* way to explain quantum effects while preserving locality. As we will see in Sections 2 and 3, dynamically unfettered BW thinking will be mandatory for explaining QLE.

We rather believe the key to rendering a BW explanation *essential* and *non-trivial* is to provide an algorithm for the relevant BW construction. Thus, the answer to: “Why did event X follow Y and Z?” is not merely, “Because X is already ‘there’ in the future of Y and Z per the BW,” but as we will illustrate, “Because this must be the spatiotemporal relationship of X, Y and Z in the BW per the self-consistent definition of the entities involved in X, Y and Z.” If one chooses to read dynamical stories from a BW picture, one may where necessary or feasible. However, BW descriptions are not limited to the depiction of dynamical/causal phenomena, so they are not constrained to dynamical/causal storytelling. In the following passage, Dainton paints a suggestive picture of what it means to take the BW perspective seriously both ontologically and methodologically:

Imagine that I am a God-like being who has decided to design and then create a logically consistent universe with laws of nature similar to those that obtain in our universe ... Since the universe will be of the block-variety I will have to create it *as a whole*: the beginning, middle and end will come into being together ... Well, assume that our universe is a static block, even if it never ‘came into being’, it nonetheless exists (timelessly) as a coherent whole, containing a globally consistent spread of events. At the weakest level, “consistency” here simply means that the laws of logic are obeyed, but in the case of universes like our own, where there are universe-wide laws of nature, the consistency constraint is stronger: everything that happens is in accord with the laws of nature. In saying that the consistency is “global” I mean that the different parts of the universe all have to fit smoothly together, rather like the pieces of a well-made mosaic or jigsaw puzzle (Dainton, 2001, p. 119).

Does reality contain phenomena which *strongly suggest* an acausal-global-constraint-BW-algorithm? According to RBW, standard EPR correlations, other quantum oddities such as eraser experiments and the delayed choice experiment for example provide reason to answer in the affirmative, but QLE demands such an answer especially if locality is to be preserved and consistency with SR maintained. NRQM *a la* RBW is one algorithm for depicting the self-consistent placement of such phenomena as EPR and QLE in a BW, as will be illustrated via the QLE itself. Likewise, attempting to explain all QM phenomena via dynamism precludes certain unique BW explanations rendered by RBW (e.g., Stuckey, Silberstein, & Cifone, 2008). Thus, the dynamical perspective is overly constrained because it constitutes only a proper subset of all possible BW-compatible explanations; *dynamical reality is only a proper subset of a spatiotemporally contextual reality given globally* and some QM phenomena are “mysterious” simply because they are not elements of that dynamical subset, such as QLE. The next section provides a brief overview of RBW.³

1.2. Overview of RBW

RBW provides an account of QM that resolves all the foundational issues therein (see Stuckey et al., 2008 for details). RBW rejects any kind of common-cause principle, i.e., the claim that every systematic quantum correlation between events is due to a cause that they share whether in the past or future. QM detector clicks are not evidence of microscopic dynamical/diachronic entities (with “thusness” as Einstein would say) propagating through space and impinging on the detector. Rather, detector clicks evidence rarefied subsets of geometric relations *comprising* the source, detector, beam splitters, mirrors, etc. in the entire worldtube of the experimental arrangement from initiation to outcomes (as in the case of entanglement), in an “all at once” fashion. Because for RBW, to borrow from Mermin (1998, p. 755), it is “relations all the way down” (relations not *relata* are the fundamentals as we ultimately express graph theoretically in Stuckey et al., 2008) and because our account is foundationally adynamical in that BW is *essential* to the story (the deepest explanation for quantum phenomena is not Schrödinger dynamics, i.e., we take the entire history of a system as the explanans and explanandum via acausal global determination relations), we call it the RBW. Dynamical entities and dynamical laws are emergent features in our view, not fundamental.⁴ Unlike the Everettian “quantum block” of Saunders (1993), RBW does not require the actuality of all outcomes and indeed adopts a kind of neo-statistical interpretation with respect to Schrödinger dynamics.⁵

The ontology of RBW is best characterized as a form of ontological structural realism (for details see Stuckey et al., 2008). While non-separable, RBW upholds locality in the sense that there is no action at a distance, no instantaneous dynamical or causal connection between space-like separated events and there are no space-like worldlines. As we said, RBW preserves locality with a non-separable geometric ontology of relations. The next section shows why QLE is problematic for BCQM, TSQM and local hidden variable accounts.

³ Phenomena begging to be explained in terms of acausal and adynamical global constraints are not limited to the quantum. For example, we think this is the right way to explain the self-consistency of, closed-time-like curves as well, rather than as a failure of dynamical determinism as such.

⁴ See Stuckey et al. (2008) for the RBW account of an adynamical theory (formalized using discrete graph theory) fundamental to both QM and GR that unifies the two and from which both “emerge” in an adynamical fashion.

⁵ See Stuckey et al. (2008) for the complete details on exactly how RBW fully resolves the QM measurement problem, but suffice it to say that the wavefunction description of a quantum system can be interpreted statistically because we now understand that, as far as measurement outcomes are concerned, the Born distribution has a basis in the spacetime symmetries of the experimental configuration. Each “click,” which some would say corresponds to the impingement of a particle onto a measurement device with probability computed from the wavefunction, corresponds to spacetime relations in the context of the experimental configuration. The measurement problem *exploits* the possibility of extending the wavefunction description from the quantum system to the whole measurement apparatus, whereas the “all at once” description according to RBW already includes the apparatus via the spacetime symmetries instantiated by the entire experimental configuration from initiation to outcomes. The measurement problem is therefore a non-starter in our view. The measurement problem arises because of the assumption that the dynamics are the deepest part of the explanatory story, the very heart of quantum mechanics, an assumption RBW rejects. In short, RBW provides a kinematic (pre-dynamical) solution to the measurement problem.

2. Quantum liar: trouble for BCQM, TSQM and local hidden variables

In Elitzur and Dolev's (ED) “quantum liar” experiment (Elitzur & Dolev, 2005), extrapolating from the work of Elitzur and Vaidman (1993) and Lucian Hardy (1992, 1993, 1994), ED show how “atoms” may be brought into an EPR state for which there is *no* causal connection between them in the past or the future. To see this, consider Figs. 1 and 2, as discussed by Elitzur and Dolev (2005). This is an example of an “interaction-free” measurement (IFM), in the sense that no interaction is required to extract information about the atom's state in this situation. We can summarize QLE by saying that it combines EPR-entanglement *a la* IFM (defying any common-cause principle) with a delayed-choice component. As follows, we can divide QLE into three distinct spatiotemporal phases: (1) prepare the boxes with the atoms, (2) place the boxes in the Mach-Zehnder interferometer (MZI) and turn on the lasers (Fig. 2), (3) remove the boxes after a D click and perform spin measurements on the atoms therein (if there is a C click or no click, then you must return to phase 1 and begin again). To describe the first phase of the experiment, let there be two atoms in the $|X+\rangle$ spin state, which by QM we know is a superposition of its Z-spin states, $Z-$ and $Z+$. Let this superposition be spatially divided into two separate boxes, one box containing the $Z+$ outcome and another box containing the $Z-$ outcome. Each atom's spin is now spatially divided according to its respective (though superposed) spin state, $Z-$ and $Z+$. To describe the second phase of the experiment, let there be two coherent laser sources (denoted S_1 and S_2) directed at two distant detectors (called D and C); and let there also be a beam splitter between the beams and the detectors (equidistant between them). We arrange the laser sources such that one beam passes through one box: S_1 's beam through Z_1+ while S_2 's beam passes through Z_2- . With no potentially obstructing atoms in the beams' way, the lasers are set to constructively interfere at path c , while destructively at path d . As ED show, the mere uncertainty in “which box” information suffices to entangle the atoms in the familiar EPR state when there is a D click:

$$|\Psi\rangle = \frac{1}{\sqrt{2}}(|Z+\rangle_1|Z+\rangle_2 + |Z-\rangle_1|Z-\rangle_2)$$

We can infer this because: (1) a D click entails one and only one of the beams is blocked thereby thwarting destructive interference, (2) a D click implies that one of the atoms was in its “blocking box” and the other in its “non-blocking box” and thus (3) the mere uncertainty about which atom is in which box entangles them in the EPR state as evidenced by the table of outcomes (Table 1).

Given phase 2 has produced the EPR-Bell state supra per the D click, we conduct the third phase of the experiment which is to “recombine” the spatially separated boxes (say, under a reverse magnetic

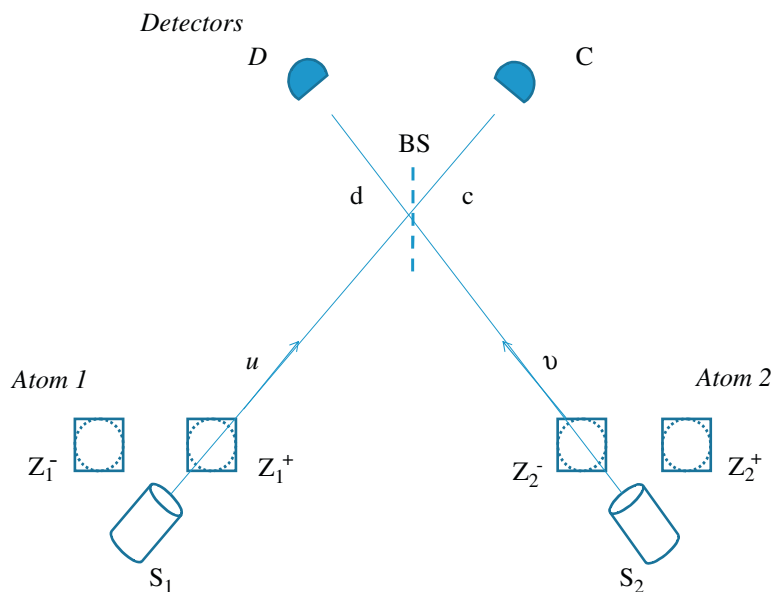

Fig. 1. Basic Quantum liar set-up, with spatially separated photon sources (based on Fig. 17.11 of Elitzur & Dolev, 2005).

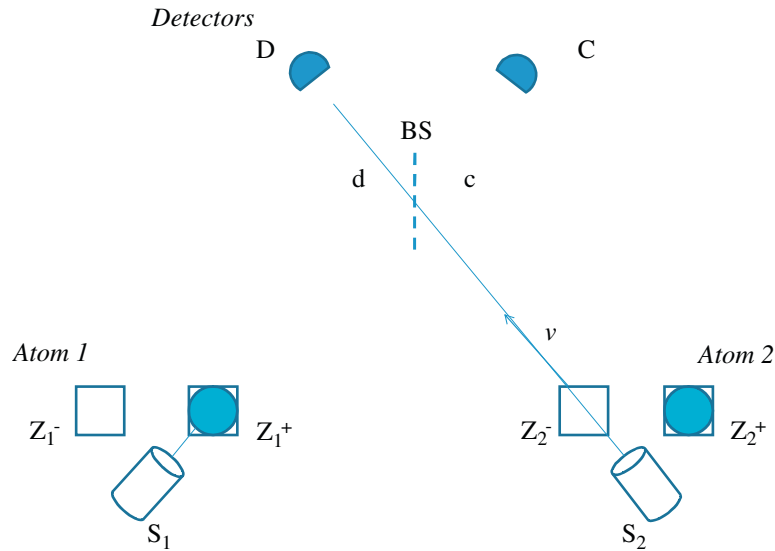

Fig. 2. Entanglement between atoms, yet no causal connection in past/future (based on Fig. 17.12 of Elitzur & Dolev, 2005).

Table 1

Particle 1	Particle 2	C click (%)	D click (%)
Z+	Z+	50	50
Z+	Z-	0	0
Z-	Z+	100	0
Z-	Z-	50	50

field) and make random spin measurements on the atoms in the Γ , Δ and Z directions (Fig. 4) as detailed by Mermin (1981). We will repeat phases 1–3 many times such that all combinations of the three spin direction measurements are performed. If we amass the results from all trials and check for correlations, we find that Bell’s inequality is violated which indicates the Z component of spin *cannot* be inferred as “a matter of definite but unknown fact” in trials prior to Γ and/or Δ measurements. This is not consistent with the apparent “matter of fact” that a “silent” detector must have existed in one of the MZI arms in order to obtain a D click, which entangled the atoms in the first place.

As ED point out, a “puzzling situation now emerges:”

In 5/9 of the cases ... (assuming random choices of measurement directions) one of the atoms will be subjected to a Z measurement—namely, checking in which box it resides. Suppose, then, that the first atom was found in the intersecting box [Fig. 2]. This seems to imply that *no photon has ever crossed that path, which is obstructed by the atom*. But then, by Bell’s proof, the other atom is still affected by the measurement of the first atom. But then again, if no photon has interacted with the first atom, the two atoms share no causal connection, in either past or future! (Elitzur & Dolev, 2005, p. 343).

The moral of this experimental possibility is that entanglement may be generated when there is no interactive point in spacetime by which we may argue that the pair was coordinated. In other words, the mere fact that the particles are arranged in a certain way, in conjunction with the fact that a photon’s path might effectively “measure” in which box our atoms reside, suffices to generate entanglement. But as should be clear by now, the situation is weirder than that. To put the point more acutely, Elitzur and Dolev (2005, p. 344) conclude their exposition of the paradox with the

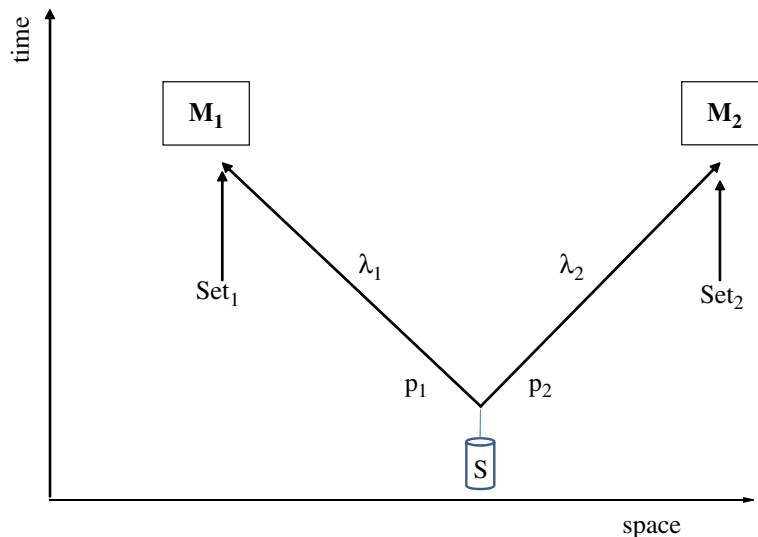

Fig. 3. Schematic spacetime diagram of basic EPR experiment.

observation that: *The very fact that one atom is positioned in a place that seems to preclude its interaction with the other atom leads to its being affected by that other atom.* In other words, *there must be a fact of the matter concerning the Z spins (i.e., a fact of the matter about the positions of the atoms in the boxes) in order to produce a state (entanglement via a D click) in which certain subsequent EPR spin measurements imply there was no fact of the matter for the Z spins.* One is tempted to say that the atoms are entangled IFF they are not.

Let us use the QLE experiment to define a particular kind of contextuality which is contained in QM—*spacetime* contextuality—and distinguish this kind from others, which are more properly called contextuality of quantum states or property contextuality.⁶ Spatiotemporal contextuality implies that entanglement can be generated via the spatiotemporal configuration of the experimental set-up in a way not explicable by any kind of common-cause principle and whose deepest explanation therefore requires invoking the entire actual history of the experiment in question. The spacetime contextuality embodied by QLE poses serious problems for BCQM, and raises very important questions for the view. As will become even clearer in Section 3, whether or not Z spin has definite values is a function of *spatiotemporal context*, a fact that would never be revealed were one handed the boxes for phase 3 measurements without knowledge of how the EPR state had been created in phases 1 and 2.

The way that BCQM was envisioned by Price seems to rely—crucially—on EPR experiments of an “interactive fork” sort, as we can easily see in Fig. 3. Such configurations allow for a natural causal interpretation of the violation of lambda-independence in the sense that we can take there to be information *causally transmitted* along the back light cone of the particles that will be (separately) measured. Causation is a backwards, time-like, entity-/particle-carried sort of process. In this case, as Price says, an explanation of EPR:

does not seem to call for any new field or bearer of the influence that one measurement exerts on another. If we think of the fate of a particle as a property of that particle—a property which has a bearing on the results of its interaction with its twin—then the particles themselves ‘convey’ the relevant influence to its common effect at the point at which they separate. (Price, 1996, p. 247).

⁶ For example, the contextuality associated with the Kochen–Specker Theorem. Notice that “spatiotemporal contextuality” may be related to KS-type contextuality, but since we are not interested in the properties of quantum states per se, but rather their placement in the context of a particular spatiotemporal arrangement (i.e., QLE), spatiotemporal contextuality is distinct from what we can call property or “quantum-state” contextuality.

The obvious problem QLE poses is the lack of an interactive fork—how does atom #1 “know” what atom #2 is doing? How is the correlation going to be (locally) pulled off if the particles share no causal connection in the past or future? We think this worry might rule out BCQM and TSQM accounts in principle, but to be charitable perhaps some specific mechanism could overcome it.

However, since no ontology is supplied, we just do not know how the trick is going to be pulled off: the devil is in the details. As Callender pointed out, Price’s BCQM suffers from not being a full-on interpretation: it is better called an “interpretation schemata” (Callender, 1998). To be a full-on interpretation requires that:

the QM formalism [be supplemented] with an ontology and with some plausible physical laws describing how this ontology behaves. This is a highly non-trivial task, requiring that one devise a ‘natural-looking’ theory that reproduces the phenomena described and predicted by QM. (Callender, 1998, p. 155).

And without this, we have no physical story which underwrites the probabilities—we have no idea what the probabilities are probabilities of. It is one thing to show—as Price does—that probabilities satisfying locality (i.e., by violating lambda-independence) are mathematically possible in principle with the addition of *some* hidden variable to the QM formalism. But it is quite another to show what that hidden variable physically is (that is what an ontology does) such that we may understand how the probabilities are *physically realized*.⁷ One thing seems certain, any account of BCQM, TSQM, etc., that requires interaction (some sort of common-cause principle) such as an “interactive fork” to explain entanglement will run afoul of QLE.

There exist at least three potential instances of BCQM-type views that (possibly) meet the desiderata for a specific mechanism suggested above: Cramer’s “transactional” interpretation (TI) and a version of TSQM centered on the now well-known “ABL rule,” which we will denote as “TSQM-ABL.” The last, and perhaps most interesting, is Peter Lewis’ recent local hidden variables theory based on the “many-histories” approach to QM, which he calls the “single-history” interpretation based on the fact that he is able to dispense with all but a single-history—the actual one. Unfortunately, Cramer and TSQM fail to provide us with an ontology that obviously and clearly satisfies Einstein locality, whereas Lewis’ view faces a number of troubling dilemmas.

2.1. TSQM-ABL and the transactional interpretation

Both Cramer’s “transactional” interpretation and the “two-vector” or the TSQM-ABL interpretation supply a concrete physical story to the abstract BCQM interpretation schemata. TSQM-ABL applies a time-symmetric boundary condition to *individual quantum states*, and thus is open to a worry about whether or not there are any non-local influences exchanged between entangled elements at space-like separation in the context of the puzzling QLE. This is because TSQM-ABL is (most plausibly) read as an “influences” instance of BCQM, as Ruth Kastner notes (1999, p. 237)⁸ and because it is unclear how the time-symmetric boundary condition *itself* is sufficient to explain the acausal local generation of EPR in QLE—especially if we stick to ordinary particles and their behavior according to the dynamics of TSQM, as most TSQM-ABL advocates do.

According to TSQM-ABL, an individual quantum state is one that has been pre- and post-selected, that is, as one to which we have applied an initial and final boundary condition (the initial boundary condition being the preparation event itself, and the final event its measurement). Thus, when we have an EPR correlation, if the TSQM-ABL view is to save locality, it must be the case that upon

⁷ Recall Butterfield’s comment that “physical reality requires something more than just successfully modeling the given statistics” and his important distinction between “mathematically possible” probabilities and “physically real” probabilities. See Butterfield (1992, p. 78); see also Dickson (1998, p. 143ff.) for a discussion. BCQM certainly demonstrates the former, whereas the latter is more obscure—and especially in the case of QLE.

⁸ Note that Kastner, following Sharp & Shanks (1993), argues quite convincingly against a counterfactual reading of the ABL rule central to TSQM-ABL, calling into question a counterfactual dependency notion of causation in this case (or at least suggesting that an account of causation in terms of counterfactual dependency cannot be tied to ABL itself). This seems to block the possibility of deploying Lewis’ preferred theory of causation for TSQM-ABL (see discussion below of Lewis’ view).

measurement, information about that measurement travels back in time to converge on the EPR state, thereby supplying that state with the requisite future boundary condition. In the case of QLE, such a convergence point in spacetime is absent, so TSQM-ABL faces the same general worry that was raised for BCQM at the beginning of this section: how do particles that share no causal connection in the past or the future communicate this future boundary condition to each other? By what local process is the time-symmetry of this EPR state generated?

Cramer's view is slightly different on this score: his is one where the wavefunction is taken realistically and time-symmetrically. In the case of a simple EPR set-up (Fig. 3), we have an "offer-wave (function)" and a "retarded-wave (function)" sent out from the point where the initial wavefunction (corresponding to the EPR state) is emitted (the source) and the point where it is absorbed (the detectors). A "transaction" is completed once both "offer" and "retarded" waves meet and they bounce back and forth until all the boundary conditions are met. But notice that this view simply puts the burden of saving Einstein locality onto the wavefunction itself. Consider the case of QLE in Fig. 2 (granting for the moment that Cramer's view can be coherently applied to this particular case). The crucial question is, what brings about the EPR correlation when neither correlated partner has shared a causal connection anywhere in spacetime? Even if the wavefunction of the photon brings about the EPR correlation between atoms 1 and 2, the photon's wavefunction will be spread out in spacetime, encompassing both atoms. Thus, if the photon's wavefunction is the medium of transmission, or the mechanism that brings about the correlation, it is non-local: one region of spacetime is non-locally connected to another via the photon's wavefunction. Given that neither atom shares a connection with the other in the past or future, then this looks to be, again, a case of side-to-side non-locality, not merely "temporal" non-locality. The upshot of all this is that denying lambda-independence (what Price calls " μ -innocence") is not sufficient to save locality.

2.2. Lewis' "single history" approach

Lewis' view (2007) lends itself to two very different interpretations: (1) a toy model of a universal wavefunction fundamentalism view without collapse (based on Gell-Mann and Hartle's (GH) "many-histories" interpretation, which is itself a variation of Everett's view) modified by a hidden variable. It is a toy model in that it models time as discrete at a scale at which there is no physical motivation for doing so. He does not say what the hidden variables are explicitly, but rather regards the many-histories formalism as a recipe for generating (time-discrete) hidden variable theories, and says "pick one of the hidden variable theories so generated." Regarding the hidden variable he suggests the following: use the many-histories recipe to make the mass density in every 10^{-5}cm^3 determinate every 10^{-5}s (i.e., the "Ghirardi ontology"). Thus we have a wavefunction evolving continuously without collapse, in addition to a stop-motion coarse-grained history, which attaches determinate mass densities to little boxes every $10e^{-5}\text{s}$. The theory generates many such histories and a probability distribution over them, but only one such history is actual. The hidden variable (the stop-motion history) puts macroscopic objects at determinate locations and thus determinate measurement results are achieved.

Though he does not say so explicitly in the article, Lewis admits he will need the actual history of the entire universe (past, present and future) as the hidden variable in order to preserve locality. This will yield a superdeterministic picture *a la* Bell in that the past does not *determine* the future, but there are facts about it anyway. As he says, it is (trivially) local, but violates Bell's independence condition. Lewis supplies a recipe for picking out a *single* history as the *actual* one, from the many sets of mutually decoherent histories implied by the GH view (Lewis, 2007, p. 1463). While the details of this recipe are not relevant here, what is important is how Lewis' view satisfies locality. Lewis claims that the single-history approach "straightforwardly ascribes probabilities to the histories" and that "since there is no interference between histories [in a simple case where the universe consists of just a single EPR experiment] ... [the] probabilities are exactly the standard Born probabilities, and hence violate the Bell inequality" (Lewis, 2007, p. 1466). Lewis also shows that his view satisfies "side-to-side" locality: the probability of the outcomes of measurements on the left side of an EPR set-up are

independent of those on the right side (recall Fig. 3). The view circumvents Bell's theorem by denying "independence" in the sense that:

the hidden variables that determine the outcome on the left are not independent of the orientation of the measuring device on the left. More precisely, the hidden variables in the single-history case—constituted by the actual history of the universe—only determine the outcomes for measurements that are actually performed along that history. (Lewis, 2007, p. 1466)

The trick that gets Lewis out of the interactive-fork problem faced by BCQM is that he takes causation to be merely *counterfactual dependency* in the case where others wish to postulate a backwards causation "mechanism," influence or process. He writes: "since the current hidden variables of the particles would have been different if the future measurements on the particles had been different, one should say that the future measurements causally influence the current hidden variables" (Lewis, 2007, p. 1467) in the sense that the states of the hidden variables counterfactually depend on future measurement acts. Thus, no influence need be realized by particles, or some new sort of entity; no information needs to be physically carried along a path in spacetime—causation *qua* counterfactual dependence is all the causation you need.

As Lewis suggests himself, there are two ways to interpret even *this first horn* of his interpretative dilemma (interpretation 1): as an instance of BCQM *a la* counterfactual causal dependence or take the violation of "independence" to be "an instance of an acausal constraint on the distribution of events in the universe" (Lewis, 2007, p. 1466). The first interpretation strikes us as no less trivial than merely asserting the fact of BW, causation as counterfactual dependence is metaphysically cheap and does not advance the actual physics of the situation per our previous discussion. Lewis might reply that the many-histories machinery makes it non-trivial but unfortunately several tough questions arise here. First and foremost, when it comes to explaining quantum phenomena and preserving locality, *why exactly* does the many-histories machinery make his view any less trivial than merely asserting BW as the explanation? There appears to be no story here about how the wavefunction *explains* or *gives rise to the* actual history. Suppose we want to know what makes one and only one of the many histories actual from the set of possible histories? On Lewis' view this is just a brute fact. Suppose we want to know what underwrites or explains the counterfactual dependencies invoked to save locality? Same answer, those relations are just a brute fact. Since this is presumably a form of wavefunction fundamentalism the lack of answers here is distressing. Furthermore, since he acknowledges the necessity and reality of BW and blockworlds by definition do not *come into* and *go out of* existence, it is hard to see in principle how the universal wavefunction could *explain* its existence in any robust or productive sense of explanation, that is, it is very hard to resist being a Humean about dynamical laws in a BW setting. Lewis can and does say the following about the wavefunction: The quantum state determines the set of histories via the Gell-Mann–Hartle formalism—one history is actual (end of story). The wavefunction *encodes* entanglement, which functions as a constraint on histories, but beyond that the wavefunction *explains* nothing. Of course, even a wavefunction anti-realist or instrumentalist can sign on to this talk about "encoding," so one would like more. Finally, it seems like the hidden variable (mass density in small cubes) is doing the real ontological work on Lewis' view.

Wavefunction fundamentalism aside, if talk of "counterfactual dependence" is going to provide a *non-trivial local explanation* for EPR and QLE, then we are owed a story as to what *underwrites* the dependency. More generally, the merely *philosophical* move of employing a counterfactual account of causation in this context does not solve the real physical and metaphysical quandary as to whether or not Einstein causality is violated by EPR and QLE—in order to answer this question we need an interpretation with the physical details elaborated. That is, both counterfactual accounts of causation and the BW are compatible with both local and non-local interpretations of QM and neutral with respect to whether or not EPR correlations conflict with the relativity of simultaneity.

The second "interpretation" (acausal global constraints) of interpretation (1) of Lewis' view obviously strikes us as the right way to go in principle but again, to avoid the charge of triviality and all the other problems of the first interpretation of (1), one must *underwrite* the global constraints in an acausal and adynamical fashion and that means providing some sort of account (such as an

adynamical and acausal hidden variable other than the universe itself!) that supercedes or relinquishes wavefunction realism and the like. What gives rise to the locality preserving acausal global constraints (what are they and where do they come from) such that the measurement problem, etc., is not a worry? Whatever the answer to this question, *by definition*, it cannot be found in the dynamics (e.g., the wavefunction) alone—on any interpretation of the dynamics. Not only does invoking acausal and adynamical global constraints to save locality entail providing some story fundamental to the dynamics, but on pain of triviality it also requires something fundamental to the fact of BW itself. And again, BW by itself does not imply locality, it depends on the nature of the BW in question. In other words, Lewis provides no story of what the locality preserving acausal global constraints are, merely that they are encoded by the wavefunction.

Lewis in conversation has kindly suggested just such an alternative and that is interpretation (2) of Lewis. On this account, the claim is that classical macroscopic objects (tables, chairs, pointers) supervene on the hidden variables and not on the wavefunction. Given the mass density ontology, the fundamental stuff that makes up the observable world is a mass density distribution, not the wavefunction. On this second interpretation, the wavefunction is just a convenient way of expressing the constraints on the possible histories of the world, nothing more. The possible histories of the world are possible ways the mass density distribution could evolve, one of them is actual—that is what underlies everything we see. Obviously, this is *not* a form of wavefunction fundamentalism. There is just a single history of the world, and the wavefunction does not *explain* it in any causal or production sense. Rather, the wavefunction explains our epistemic situation as creatures in this BW.

It should be clear that Lewis (2) has many of the same problems as Lewis (1). We still only know that the wavefunction encodes various kinds of information and explains our situatedness in the BW, but we do not know why this is the case, and we do not know what if anything beyond mere phenomenology connects the wavefunction and the BW. That is, we have been provided neither an explanation for QM nor for other features of the BW, let alone a unifying explanation of relativity and the quantum. Talk of macroscopic objects *supervening on* the mass density distribution is no less trivial than merely asserting it is a BW and everything is just “there,” again, the real hidden variable here is the entire actual history of the universe, period. And again, we still have neither been provided a story about the acausal global constraints, nor a clear non-trivial story about why or how locality is preserved beyond the invocation of counterfactual causal dependencies. As the next section shows, RBW has answers to all these questions with no lacunae. As seen in the next section, RBW *does* provide an “underwriting” story for the acausal global constraints and the probability distribution.

3. An RBW model of QLE

By limiting any account of QLE to a story about the interactions of objects or entities in spacetime (such as the intersection of point-particle-worldlines, or an everywhere-continuous process *connecting* two or more worldlines), it is on the face of it difficult to account for IFM given entanglement and preserve locality since, naively, a necessary condition for an “interaction” per particle or *thing* based physics is the “intersection of two or more worldlines.” However, since the entire spatiotemporal configuration of the IFM in QLE “generated” the entanglement, we can use spacetime symmetries to model the *entire* spacetime configuration of the experiment in a non-trivial way so as to predict and explain the EPR correlations in QLE (Stuckey et al., 2008).

Since spatiotemporal relations provide the ontological basis for our geometric interpretation of quantum theory, spacetime symmetries provide the explanation (*qua* mathematical description) of quantum phenomena. That is, the distribution of clicks at the detectors reflects the spatiotemporal relationships between the source, beam splitters, mirrors and detectors as described by the spacetime symmetry group—spatial translations and reflections in this case. The relevant 2D irreducible representations (irreps) for one-dimensional translations and reflections are

$$T(a) = \begin{pmatrix} e^{-ika} & 0 \\ 0 & e^{ika} \end{pmatrix} \quad \text{and} \quad S(a) = \begin{pmatrix} 0 & e^{-2ika} \\ e^{2ika} & 0 \end{pmatrix}$$

respectively, in the eigenbasis of T , and *these are the fundamental elements of our geometric description of the MZI in the Heisenberg formalism*. In Stuckey et al. (2008) we show the density operator of an experimental configuration can be obtained from the “past, present and future” of the entire spatiotemporal configuration *a la* the spacetime symmetries of the experimental set-up: from the initiation of the experiment to its outcomes (as is clear also, for example, in our path-integral formalism). With this ontology of spatiotemporal relations, the matter–geometry dualism has been collapsed per ontological structural realism such that both “object” and “influence” reduce to *spacetime* relations for the purposes of modeling QLE. In our path-integral approach, for example, “entanglement” is seen as correlated outcomes in an “all at once” description of the experiment per the symmetries of the action (Stuckey & Silberstein, 2008). Note there is no mention of photon interference here. We are simply describing the distribution of events (clicks) in spacetime (spatial projection, rest frame of MZI) using the fundamental ingredients in this type of explanation, i.e., spacetime symmetries (spatial translations and reflections in the MZI, rotations in the case of spin measurements). What it means to “explain” a phenomenon in this context is to provide the distribution of spacetime events per the spacetime symmetries relevant to the experimental configuration, so RBW constitutes an *acausal* and *adynamical* characterization and global (kinematical or geometrical) explanation of entanglement.

3.1. *Relata and relations*

Since RBW is predicated upon the claim that dynamic entities, e.g., particles and fields, are not ontologically fundamental, it is incumbent upon us to provide, if only heuristically, a means by which dynamic entities might be constructed via relations. We have done so elsewhere (Stuckey & Silberstein, 2008) using a discrete path-integral formalism over graphs based on the self-consistent definition of trans-temporal objects, space and time. In summary, self-consistency principle → discrete action → symmetry amplitude (“discrete transition amplitude” in the parlance of quantum field theory). This provides conceptually, if not analytically, a basis for the RBW ontology and methodology, enumerated as follows:

1. Each piece of equipment in an experimental set-up results from a large number of spatiotemporally dense relations, so low-intensity sources and high-sensitivity detectors must be used to probe the realm of rarefied relations described by QM.
2. A “detector click” is a subset of the detector that also results from a large number of spatiotemporally dense relations; we infer the existence of a rarified set of relations between the source and the detector at the beginning of the click’s worldline.
3. It is this inferred, rarified set of relations for which we compute the symmetry amplitude.
4. A symmetry amplitude must be computed for each of all possible click locations (experimental outcomes) and this calculation must include (tacitly if not explicitly) all relevant information concerning the spacetime relationships (e.g., distances and angles) and property-defining relations (e.g., degree of reflectivity) for the experimental equipment per the action.
5. The relative probability of any particular experimental outcome can then be determined by squaring the symmetry amplitude for each configuration (which includes the outcomes) and normalizing over all configurations.

3.2. *QLE and blockworld*

Our analysis of QLE shows the explanatory necessity of the reality of all events—in this case the reality of all phases of the QLE experiment. We can provide an illustrative, though qualitative summary by referring to three phases of QLE in Figs. 5 and 6. Again, in the first phase the boxes Z_{1+} , Z_{1-} , Z_{2+} and Z_{2-} are prepared (turned into “silent” detectors of sorts), in the second phase the four boxes are placed in the MZI per Fig. 2 and a D click is obtained and in the third phase the boxes are subjected to EPR spin measurements (Fig. 4).

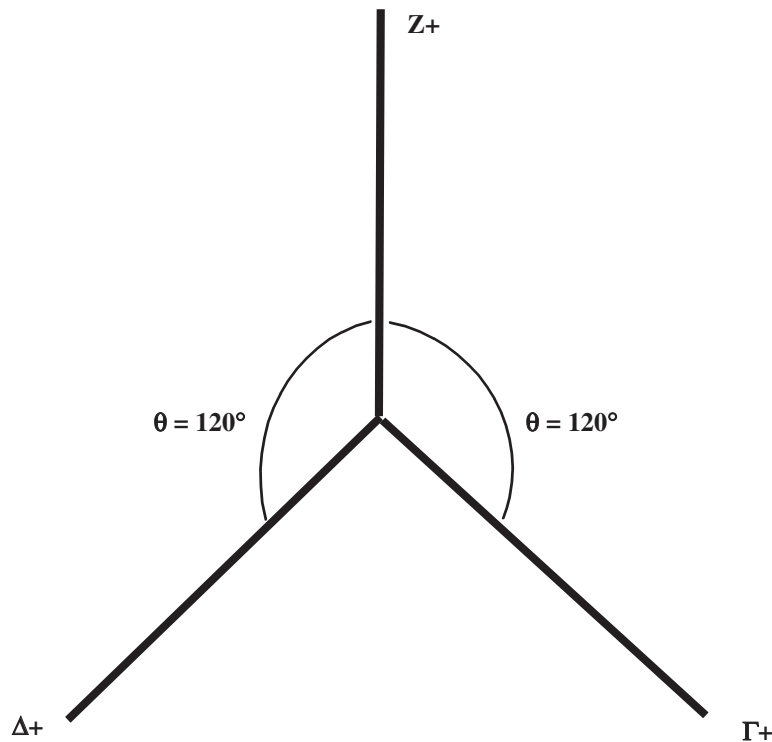

Fig. 4. Stern-Gerlach angles for spin measurements in the Y-Z plane.

We are not describing “photons” moving through the MZI or “atoms” whose spin states are being measured. According to our ontology, clicks are evidence not of an impinging particle-in-motion, but of rarified relations which are a subset of the dense set comprising the equipment of the experiment. If a Z measurement is made on either pair of boxes in phase 3, an inference can be made *a posteriori* as to which box acted as a “silent” detector in phase 2 (Fig. 6). If Γ and/or Δ measurements are done on each pair (Fig. 5), then there is *no fact of the matter* concerning the detector status of the original boxes. This is not simply a function of ignorance because if it was possible to identify the “silent” detectors before the Γ and/or Δ measurements were made, the Bell assumptions would be met and the resulting spin measurements would satisfy the Bell inequality. Therefore, *that none of the four boxes can be identified as a detector in phase 2 without a Z measurement in phase 3 is an ontological, not epistemological, fact* and points to the necessity of, if you will, an “all at once” BW explanation. Notice that what obtains in phase 3 “determines” what obtains in phase 2, so we have a true “delayed-choice” experiment. For example, suppose box Z_2- is probed in phase 3 (Z measurement) and an event is registered (an “atom resides therein,” Fig. 6). Then, the Z_2- and Z_1- boxes are understood during phase 3 to be detectors in phase 2. However, nothing in the BW has “changed”—the beings in phase 2 have not “become aware” of which boxes are detectors. Neither has anything about the boxes in phase 2 “changed.” According to our view, the various possible spatiotemporal distributions of events are each determined by QM *as a whole throughout space and time*.

4. Conclusion

In Figs. 5 and 6, one can chart implications from phase 1 to phase 3 then back to phase 2, since the order in which we chart implications in a spacetime diagram is meaningless (meta-temporal) to the BW inhabitants. In point of fact, the collective characteristics in all three phases of QLE are acausally and globally (without attention to any common-cause principle) determined by the spacetime symmetries of the *entire actual history* of the experimental set-up; hence, the *non-trivial* explanatory necessity of the BW. What *determines* the outcomes in QLE is not given in terms of influences or

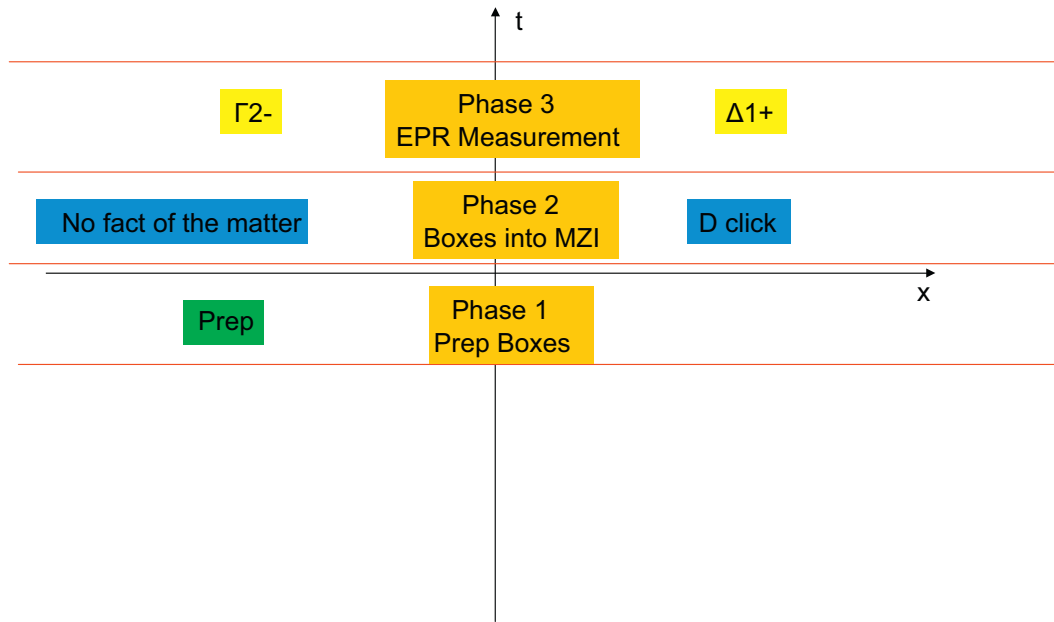

Fig. 5. Experimental sequence consistent with no spin measurements in the Z direction after a D click.

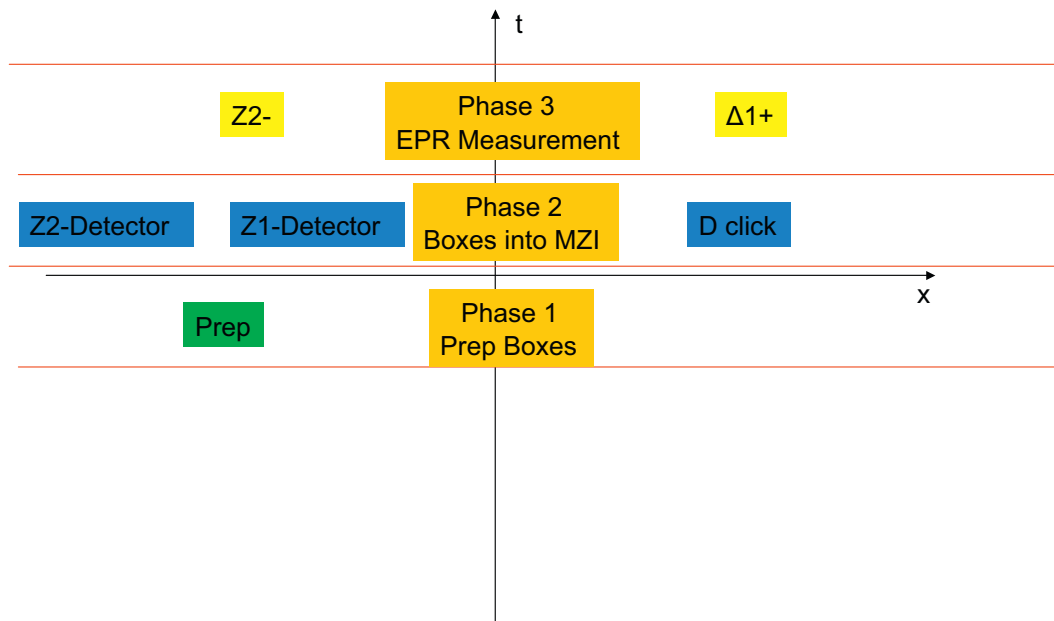

Fig. 6. Experimental sequence consistent with a spin measurement in the Z direction after a D click.

causes (in any sense of the word). In this way, we resolve the quantum liar paradox locally with RBW by showing how “the paradox” is not only *consistent* with a BW structure, but, if locality is to be preserved, actually demands an adynamical interpretation such as ours over interpretations involving dynamical entities and their histories whether forwards or backwards in time. It is the *spatiotemporal configuration of QLE as a spacetime whole and its spacetime symmetries* that determine the outcomes and not *constructive (a la Einstein) entities with dynamical histories*. As far as we know, RBW is the only fully developed truly acausal and local account of QM consistent with SR that explains quantum entanglement and resolves the measurement problem. The key to all this is taking seriously the idea that the deepest story underneath QM is an adynamical one.

RBW embraces fundamentally a realism of structure, not trans-temporal *entities* or *things* and, accordingly, adopts a form of *structural explanation* that is acausal and adynamical in nature. RBW is also fundamentally atemporal, in that the reality of all events plays an *essential* explanatory role. It is

sometimes pointed out that structural explanation is most clearly understood by considering examples from SR, examples such as the well-known relativistic phenomena of length contraction and time dilation. Viewed as a “principle” theory, following Einstein’s famous remarks, SR introduces, as Jeffrey Bub put it, “abstract structural constraints that events are held to satisfy” (as cited in Hughes, 1989). Regarding the phenomenon of length contraction, to explain is to, as Hughes put it,

[sketch] the models of space-time which special relativity provides and [to show] that in these models, for a certain family of pairs of events [say, the events that constitute the ends of a moving rod], not only is their spatial separation x proportional to their temporal separation t , but the quantity x/t is invariant across [inertial] coordinate systems; further for all such pairs, x/t always has the same value. (Hughes, 1989, p. 257).

The crucial point here is that *causality does not figure into the analysis of length contraction*, yet explanation can nonetheless be had. As Hughes says,

This [explanation] makes no appeal to causality; rather it points out structural features of the models special relativity provides. It is, in fact, an example of structural explanation (Hughes, 1989, p. 257).

Hughes thinks that “explanation comes at many levels,” and that, at the “foundational level” to explain is simply to show that certain abstract structural features must be satisfied by any model of the theory in question (Hughes, 1989). But—and this is where Hughes’ embrace of structural explanation is left wanting—what sort of *ontology* might we supply for SR such that causal or dynamical explanations are obviously not fundamental, unhelpful, irrelevant or, as he says, “misleading” We are left wanting a *realistic* explanation of the phenomenon of length contraction, in terms of a *physical ontology* whose behavior is determined by dynamical laws of motion—a “constructive” account. It is the physical ontology behaving in accordance with the dynamical laws of nature that we are “designed” to find illuminating or explanatory; not the instantiation of abstract mathematical structures. Structural explanation has some precedent in the interpretation of quantum theory (see, for example, the discussion in Hughes, 1989, p. 256ff.), but again, it is often plagued by the fact of an unclear or absent ontology, and so it is open to the objection that what structural “explanations” provide are just mathematical descriptions parading as explanations. We hope our analysis of QLE *a la* RBW will go some way towards loosening the grip of “constructive,” dynamical, temporal and causal biases in fundamental physics.

References

- Aharonov, Y., Bergmann, P., & Lebowitz, J. (1964). Time symmetry in the quantum process of measurement. *Physical Review*, 134B, 1410–1416.
- Aharonov, Y., Botero, A., Popescu, S., Reznik, B., & Tollaksen, J. (2002). Revisiting Hardy’s paradox: Counterfactual statements, real measurements, entanglement and weak values. *Physics Letters A*, 301, 130–138.
- Barrett, J. A. (2005). Relativistic quantum mechanics through frame-dependent constructions. *Philosophy of Science*, 72(December), 802–813.
- Butterfield, J. (1992). Bell’s theorem: What it takes. *British Journal for the Philosophy of Science*, 43, 41–83.
- Callender, C. (1998). The view from no-when (review of time’s arrow and archimedes’ point: New directions for the physics of time). *British Journal for the Philosophy of Science*, 49, 135–159.
- Cramer, J. (1980). Generalized absorber theory and the EPR paradox. *Physical Review D*, 22, 362–376.
- Cramer, J. (1986). The transactional interpretation of quantum mechanics. *Review of Modern Physics*, 58, 647–687.
- Dainton, B. (2001). *Time and space*. Montréal: McGill-Queen’s University Press.
- Dickson, W. M. (1998). *Quantum chance and non-locality*. Cambridge: Cambridge University Press.
- Einstein, A., Podolsky, B., & Rosen, N. (1935). Can quantum-mechanical description of physical reality be considered complete? *Physical Review*, 47, 777–780.
- Elitzur, A. C., & Dolev, S. (2005). Quantum phenomena within a new theory of time. In A. Elitzur, S. Dolev, & N. Kolenda (Eds.), *Quo vadis quantum mechanics?* (pp. 325–349). Berlin: Springer.
- Elitzur, A. C., & Vaidman, L. (1993). Quantum mechanical interaction-free measurements. *Foundations of Physics*, 23, 987–997.
- Hardy, L. (1992). On the existence of empty waves in quantum theory. *Physics Letters A*, 167, 11–16.
- Hardy, L. (1993). Nonlocality for two particles without inequalities for almost all entangled states. *Physical Review Letters*, 71, 1665–1668.
- Hardy, L. (1994). Nonlocality of a single photon revisited. *Physical Review Letters*, 73, 2279–2283.

- Hughes, R. (1989). *The structure and interpretation of quantum mechanics*. Cambridge: Harvard University Press.
- Kastner, R. (1999). Time-symmetrised quantum theory, counterfactuals, and 'advanced action'. *Studies in the History and Philosophy of Modern Physics*, 30(2), 237–259.
- Lewis, P. (2006). Conspiracy theories of quantum mechanics. *British Journal of the Philosophy of Science*, 57, 359–381.
- Lewis, P. (2007). Towards a local hidden variable theory. *Foundations of Physics*, 37, 461–469.
- Mermin, D. (1981). Bringing home the atomic world: Quantum mysteries for anybody. *American Journal of Physics*, 49(10), 940–943.
- Mermin, D. (1998). What is quantum mechanics trying to tell us? *American Journal of Physics*, 66, 753–767.
- Price, H. (1996). *Time's arrow and Archimede's point*. Oxford: University Press (p. 260).
- Price, H. (2007). Causal perspectivalism. In H. Price, & R. Cory (Eds.), *Causation, physics, and the constitution of reality: Russell's republic revisited* (pp. 250–292). Oxford: Oxford University Press.
- Saunders, S. (1993). Decoherence, relative states and evolutionary adaptation. *Foundations of Physics*, 23, 1553–1585.
- Sharp, W., & Shanks, N. (1993). The rise and fall of time-symmetrized quantum mechanics. *Philosophy of Science*, 60, 488–499.
- Stuckey, W. M., & Silberstein, M. (2008). Unification per the relational blockworld. [quant-ph/0712.2778](https://arxiv.org/abs/quant-ph/0712.2778).
- Stuckey, W. M., Silberstein, M., & Cifone, M. (2008). Reconciling spacetime and the quantum: Relational blockworld and the quantum liar paradox. *Foundations of Physics*, 38(4), 348–383.
- Wharton, K. B. (2007). Time-symmetric quantum mechanics. *Foundations of Physics*, 37(1), 159–168.